

Issue Date: 08-30-2018
Revised Date: 08-30-2019
Renewal Date: 08-30-2020

DIVISION: 05 00 00 – METALS
Section: 05 52 00 – Metal Railings

REPORT HOLDER:
Ultra Aluminum Manufacturing, Inc.
2124 Grand Commerce Drive
Howell, MI 48855
(800) 656-4420
www.ultrafence.com

REPORT SUBJECT:
Ultra Max Adams Guardrail System
Signature Adams Guardrail System
Juliette Balcony

1.0 SCOPE OF EVALUATION

1.1 This Research Report addresses compliance with the following Codes:

- 2015 *International Building Code*® (IBC)
- 2015 *International Residential Code*® (IRC)
- 2017 *Florida Building Code* (see Section 9)

1.2 Ultra Aluminum guardrail systems have been evaluated for the following properties:

- Structural Performance

1.3 Ultra Aluminum guardrail systems have been evaluated for the following uses (see Table 1):

- The Ultra Aluminum guardrail systems are guardrails under the definitions of the referenced codes. It is intended for use at or near the open sides of elevated walking areas of buildings and walkways as required by the codes.
- Guardrails are provided as level guardrails for level walking areas such as decks, balconies, and porches.

2.0 STATEMENT OF COMPLIANCE

The Ultra Aluminum guardrail systems comply with the Codes listed in Section 1.1, for the properties stated in Section 1.2 and uses stated in Section 1.3, when installed as described in this report, including the Conditions of Use stated in Section 6.

3.0 DESCRIPTION

3.1 The Ultra Aluminum guardrail systems are an assemblage of extruded aluminum top and bottom rails, balusters, structural aluminum posts, rail to post brackets and decorative moldings and post caps. Guardrails are provided with rail lengths and installed heights as identified in Table 2.

3.1.1 The top rails consist of extruded aluminum profiles. See Figure 1.

3.1.1.1 The *Signature Adams* top rail is an assembly of two extruded aluminum profiles; a cap snap fitted over a support rail, with nominal dimensions of 1-11/16-inch-high by 1-11/16 inch wide.

3.1.1.2 The *Ultra Max Adams* top rail is an extruded aluminum profile with nominal dimensions of 1-11/16-inch-high by 1-11/16 inch wide.

3.1.1.3 The *Juliette Balcony* top rail is an extruded aluminum profile with nominal dimensions of 1.337 inches high by 2.25 inches wide.

3.1.2 The bottom rails consist of extruded aluminum profiles. See Figure 2.

3.1.2.1 The *Signature Adams* bottom rail assembly consists of two extruded aluminum profiles, a cap snap fitted over a support rail. Overall dimensions of the assembly are 1.32 inches tall and 1.35 inches wide.



3.1.2.2 The *Ultra Max Adams* top rail is an extruded aluminum profile with nominal dimensions of 1.25 inches tall by 1.375 inches wide.

3.1.2.3 The *Juliette Balcony* top rail is an extruded aluminum profile with nominal dimensions of 1.337 inches high by 2.25 inches wide.

3.1.3 The *Ultra Max* and *Signature Adams* top and bottom rails are attached to 2 inch, 2-1/2 inch and 3-inch aluminum posts with cast aluminum collar brackets. See Figure 4.

3.1.3.1 The 2-inch square posts are extruded aluminum tube, with a nominal wall thickness of 0.125 inches and four raceway channels running the length of the post. The tube is permanently attached to a 4-inch square, 1/2 inch thick aluminum base plate via both a 1/4-inch continuous fillet weld and four 1/4-20 by 1 inch long, trim head, Type F thread cutting, stainless steel screws. See Figure 6.

3.1.3.2 The 2-1/2-inch square posts are extruded aluminum tube, with a nominal wall thickness of 0.10 inches and four raceway channels running the length of the post. The tube is permanently attached to a 5-inch square, 3/8-inch-thick aluminum base plate via both a 1/4-inch continuous fillet weld and four 1/4-20 by 1 inch long, trim head, Type F thread cutting, stainless steel screws. See Figure 7.

3.1.3.3 The 3-inch square posts are extruded aluminum tube, with nominal wall thickness of 0.125 inches and six or four raceway channels running the length of the post. The six raceway tube is permanently attached to a 5-inch square, 1/2 inch thick aluminum base plate via both a 3/8-inch continuous fillet weld and six 1/4-20 by 2-inch-long, trim head, Type F thread cutting, stainless steel screws. The four raceway tube is permanently attached to a 5-inch square, 3/8-inch-thick aluminum base plate via both a 3/8-inch continuous fillet weld and four 1/4-20 by 1 inch long, trim head, Type F thread cutting, stainless steel screws. See Figures 8 and 9.

3.1.4 The *Juliette Balcony* rail assembly is attached to the primary structure via a prefabricated corner bracket assembly. The corner bracket assembly consists of two balusters, top and bottom rail corners, corner gussets, and 4-inch square aluminum plates. The rail corner are two

permanently welded rails via a 1/4 inch continuous fillet weld at the corner joint. A corner gusset is permanently welded to the inside corner of the rail with 1/4 inch fillet welds 1 inch in length on the top edge, and of the gusset, and 1-1/2 inch in length on the bottom edge at each location where the gusset meets the rail. At the end of the rail where it meets the rail plate, the components are permanently welded via a 1/4 inch continuous fillet weld. See Figure 5.

3.1.5 Infill consists of 0.75-inch square, hollow, extruded aluminum balusters, with nominal wall thickness of 0.05 inches.

3.1.5.1 *Ultra Max Adams* and *Signature Adams* balusters are secured to top rails with high-density-polyethylene baluster plugs. Balusters are inserted into routed holes in the bottom rails. See Figure 3 .

3.1.5.2 *Juliette Balcony* balusters are secured to top and bottom rails by a 1/4-inch fillet weld, 3/4 inches in length on two sides. See Figure 3.

4.0 PERFORMANCE CHARACTERISTICS

4.1 The guardrail system described in this report has demonstrated the capacity to resist the design loadings specified in Chapter 16 of both the IBC and Section R301 of the IRC when tested in accordance with ICC-ES AC273.

5.0 INSTALLATION

5.1 Ultra Aluminum guardrail systems must be installed in accordance with the manufacturer's published installation instructions, the applicable Code, and this Research Report. A copy of the manufacturer's instructions must be available on the jobsite during installation.

5.2 The *Ultra Max Adams* and *Signature Adams* top and bottom rails are attached directly to structural posts utilizing cast aluminum mounting brackets via mechanical fasteners. See Table 3 for the fastening schedule. Infill aluminum balusters are inserted onto 0.66-inch diameter HDPE plugs. See Figure 5 for the *Juliette Balcony*, the balusters are permanently secured to the top and bottom rails by a 1/4 inch fillet weld, 3/4 inches long on two sides



of the baluster that are perpendicular to the length of the guardrail.

5.3 The *Juliette Balcony* top and bottom rails are attached directly to structural posts utilizing a prefabricated corner bracket assembly. See Table 3 for the fastening schedule and Figure 10. See Section 6.3 for conditions of use.

6.0 CONDITIONS OF USE

6.1 Installation must comply with this Research Report, the manufacturer’s published installation instructions, and the applicable Code. In the event of a conflict, this report governs.

6.2 Attachment of guardrail systems described herein to conventional wood supports is outside the scope of this report.

6.3 Anchorage of the *Juliette Balcony* and structural guardrail posts are not within the scope of this report and are subject to evaluation and approval by the building official. Anchors must satisfy the design load requirements specified in Chapter 16 of the building code and must meet the following minimum requirements:

6.3.1 A minimum of four anchor bolts must be used and located in the four pre-drilled holes in *Juliette Balcony* brackets and the structural guardrail post base plate.

6.3.2 The anchors must have a minimum nominal diameter equal to 3/8 inch.

6.3.3 When the supporting structure is a wood-framed deck or wall, installation must include anchorage to suitable structural framing. Decking and wall sheathing are not considered structural framing, and anchorage to decking or sheathing alone is not an approved installation method.

6.4 Where required by the building official, engineering calculations and details shall be provided. The calculations shall verify that the anchorage and supporting structure complies with the building code for the type and condition of the supporting construction.

6.5 Where aluminum is in contact with dissimilar materials, direct contact between the aluminum and the other material shall be prevented by factory finish or a heavy coat of alkali-resistant bituminous paint or other coating providing the equivalent protection before installation.

6.6 Compatibility of fasteners and other metallic components with the supporting structure, including chemically treated wood, is outside the scope of this report.

6.7 The Ultra Aluminum guardrail systems are manufactured under a quality control program with inspections by Intertek Testing Services NA, Inc.

7.0 SUPPORTING EVIDENCE

7.1 Drawings and installation instructions submitted by Ultra Aluminum Inc.

7.2 Data demonstrating compliance with the performance requirements of ICC-ES AC273, Acceptance Criteria for Handrails and Guards, revised March 2016 with additional testing including increased test loads to address IBC.

7.3 Documentation of an Intertek approved quality control system for the manufacturing of products recognized in this report.

8.0 IDENTIFICATION

The Ultra Aluminum guardrail systems that are described in this report shall be identified with labeling bearing the report holder’s name (Ultra Aluminum Manufacturing, Inc.), the Intertek mark, and the Code Compliance Research Report number (CCRR-0278) and the following statement: “See CCRR-0278 at whdirectory.intertek.com for uses and performance levels.”





9.0 FLORIDA BUILDING CODE

9.1 Scope of Evaluation:

The Ultra Aluminum guardrail systems were evaluated for compliance with the *Florida Building Code – Building* and *Florida Building Code – Residential*.

9.2 Conclusion:

The Ultra Aluminum guardrail systems, described in Sections 2.0 through 7.0 of this Research Report, comply with the *Florida Building Code – Building* and *Florida Building Code – Residential*, including High Velocity Hurricane Zone (HVHZ).

9.3 Intertek is a Florida State Product Evaluation Entity.

10.0 CODE COMPLIANCE RESEARCH REPORT USE

10.1 Approval of building products and/or materials can only be granted by a building official having legal authority in the specific jurisdiction where approval is sought.

10.2 Code Compliance Research Reports shall not be used in any manner that implies an endorsement of the product by Intertek.

10.3 Reference to the <https://bpdirectory.intertek.com> is recommended to ascertain the current version and status of this report.

This Code Compliance Research Report (“Report”) is for the exclusive use of Intertek’s Client and is provided pursuant to the agreement between Intertek and its Client. Intertek’s responsibility and liability are limited to the terms and conditions of the agreement. Intertek assumes no liability to any party, other than to the Client in accordance with the agreement, for any loss, expense or damage occasioned by the use of this Report. Only the Client is authorized to permit copying or distribution of this Report and then only in its entirety, and the Client shall not use the Report in a misleading manner. Client further agrees and understands that reliance upon the Report is limited to the representations made therein. The Report is not an endorsement or recommendation for use of the subject and/or product described herein. This Report is not the Intertek Listing Report covering the subject product and utilized for Intertek Certification and this Report does not represent authorization for the use of any Intertek certification marks. Any use of the Intertek name or one of its marks for the sale or advertisement of the tested material, product or service must first be approved in writing by Intertek.





TABLE 1 – PROPERTIES EVALUATED

PROPERTY	2015 IBC SECTION	2015 IRC SECTION	2017 FBC - Building	2017 FBC-Residential
Structural Performance	1607.8	R301.5	1607.8	R301.5

TABLE 2 – GUARDRAIL SYSTEMS AND USE CATEGORIES

Aluminum Guardrail System	Guardrail Type	Maximum Guardrail Dimensions	Support Post Mount System	Code Occupancy Classification
<i>Ultra Max Adams Signature Adams</i>	Level	61-7/16 inches by 42 inches ⁽¹⁾	2-inch post	IBC and FBC IRC and FBC-Residential
		62-1/2 inches by 42 inches ⁽¹⁾	2-1/2-inch post	
		80-1/2 inches by 42 inches ⁽¹⁾	3-inch post (four screw bosses)	
		97-1/4 inches by 42 inches ⁽¹⁾	3-inch post (six screw bosses) ⁽³⁾	
		97-1/4 inches by 36 inches ⁽¹⁾	2-inch post	The use of this product shall be limited to exterior use as a guardrail system for balconies and porches for one- and two-family dwellings (IBC, FBC) construction in accordance with the IRC or FBC-Residential.
			2-1/2-inch post	
			3-inch post (four screw bosses)	
<i>Juliette Balcony</i>	Level	128 inches by 42 inches ⁽²⁾	Primary structure ⁽⁴⁾	IBC and FBC IRC and FBC-Residential

¹ Guardrails are qualified up to and including the listed maximum guardrail system dimensions for use in the referenced Code Occupancy Classification. Guardrail length is actual railing length, i.e. clear space between supports for level rails. Guardrail height is walking surface to top of top rail.

² Juliette Balcony is qualified up to and including the listed maximum guardrail system dimensions for use in the referenced Code Occupancy Classification. Guardrail length is measured from the outside edge of each of the corner rails.

³ The 3-inch post with the six screw bosses may be installed in either orientation where the two sets of three screw bosses are perpendicular or parallel to the span of the guardrail.

⁴ The top and bottom rails of the Juliette Balcony are attached directly to the primary structure. Anchorage of the top and bottom rails are not within the scope of this report and are subject to evaluation and approval by the building official. Anchors must satisfy the design load requirements specified in Chapter 16 of the building code. See Section 6.3.

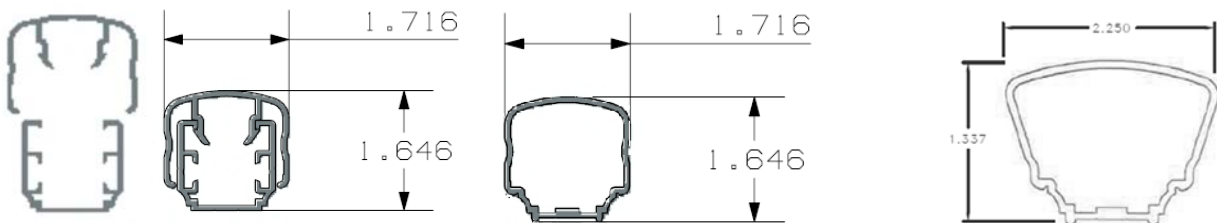



TABLE 3 – FASTENER SCHEDULE

Guardrail	Connection	Fastener ¹
<i>Ultra Max Adams Signature Adams</i>	Rail Bracket to Post	Two 1/4-14 x 1 inch (0.185 in minor diameter) flat-head, self-drilling, stainless steel screws
	Rail Bracket to Rail	One 1/4-14 x 1 inch (0.185 in minor diameter) flat-head, self-drilling, stainless steel screws
	HDPE Baluster Plug to Top Rail	One 3/16-inch diameter aluminum body with steel mandrel blind rivet
	Baluster to Bottom Rail	Slip fit into routed hole
	Support Block Baluster Plug to Bottom Rail	One #8-18 x 1-inch (0.117 in minor diameter) pan head, self-drilling, coated steel screw
<i>Juliette Balcony</i>	Top Rail to Corner Bracket Assembly	One 1/4-13 x 1 inch (0.184 in minor diameter) trim head, self-drilling, stainless steel screw
	Bottom Rail to Corner Bracket Assembly	One 1/4-13 x 1 inch (0.184 in minor diameter) trim head, self-drilling, stainless steel screw
	Picket to Top/Bottom Rail	1/4-inch fillet weld, 3/4 inches in length on two sides

¹ All self-drilling stainless steel screws are 300 series stainless steel.



Signature Adams

Ultra Max Adams

Juliette

Figure 1 – Top Rail Profiles

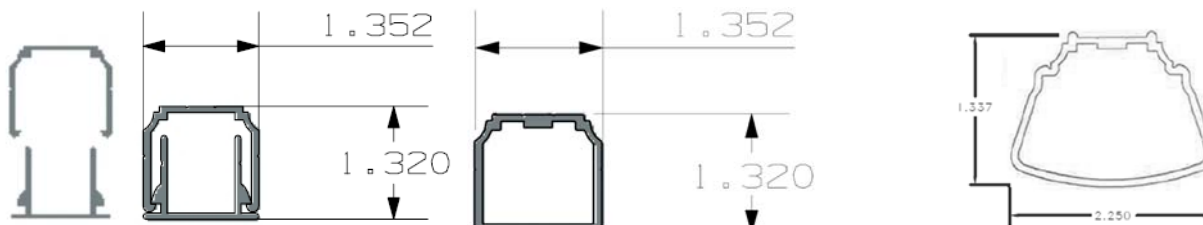

Signature Adams

Ultra Max Adams

Juliette

Figure 2 – Bottom Rail Profiles



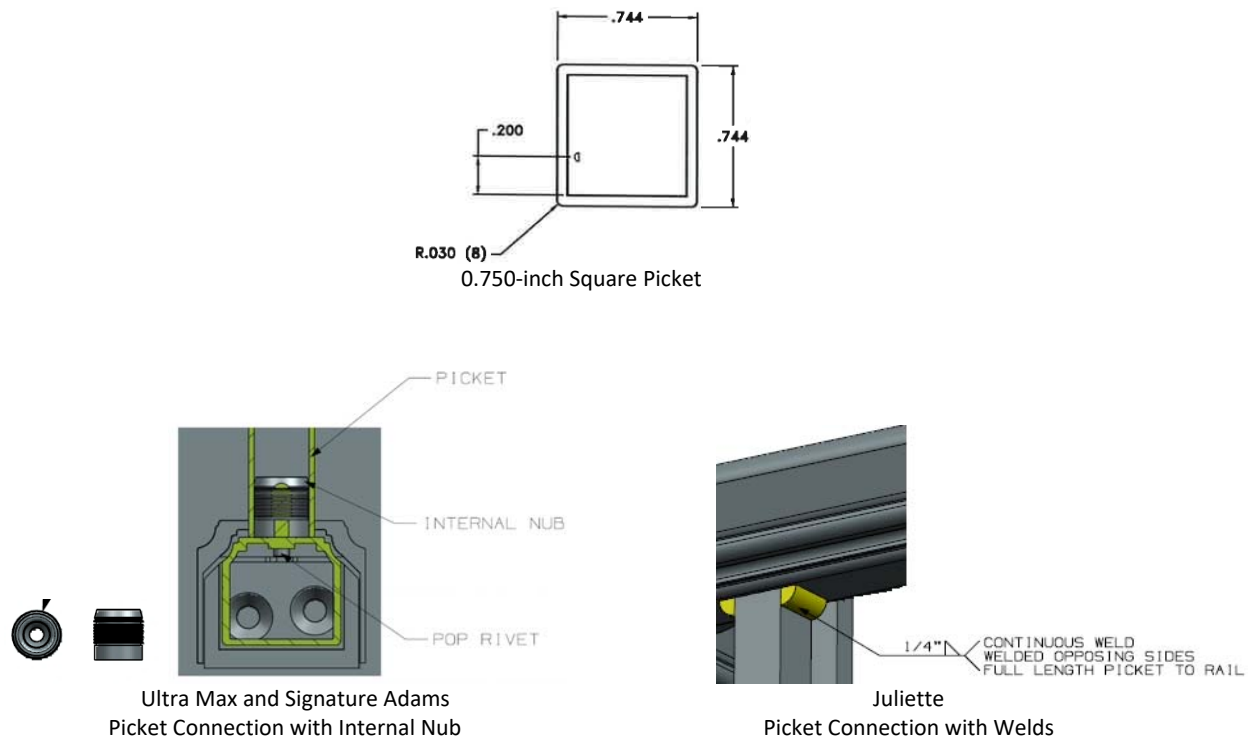

Figure 3 – Infill

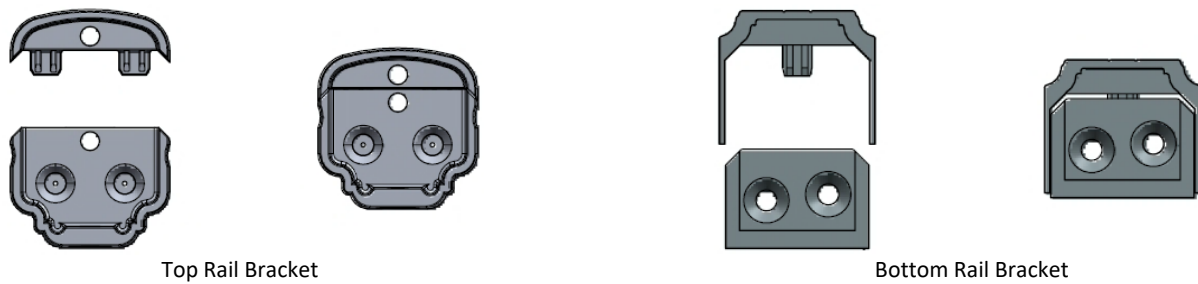

Figure 4 – Ultra Max and Signature Adams Brackets

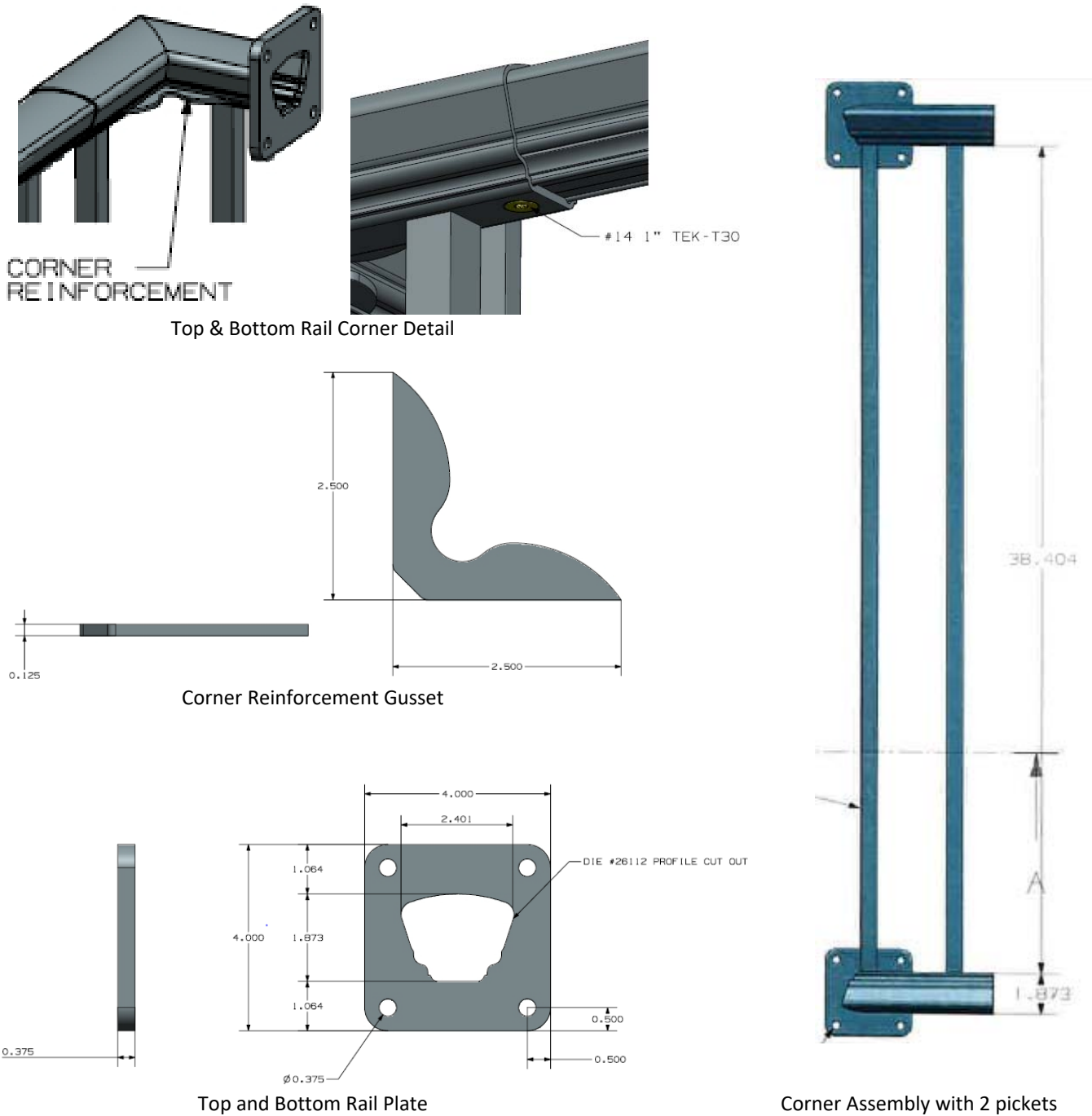

Figure 5 – Juliette Balcony Corner Bracket Assembly

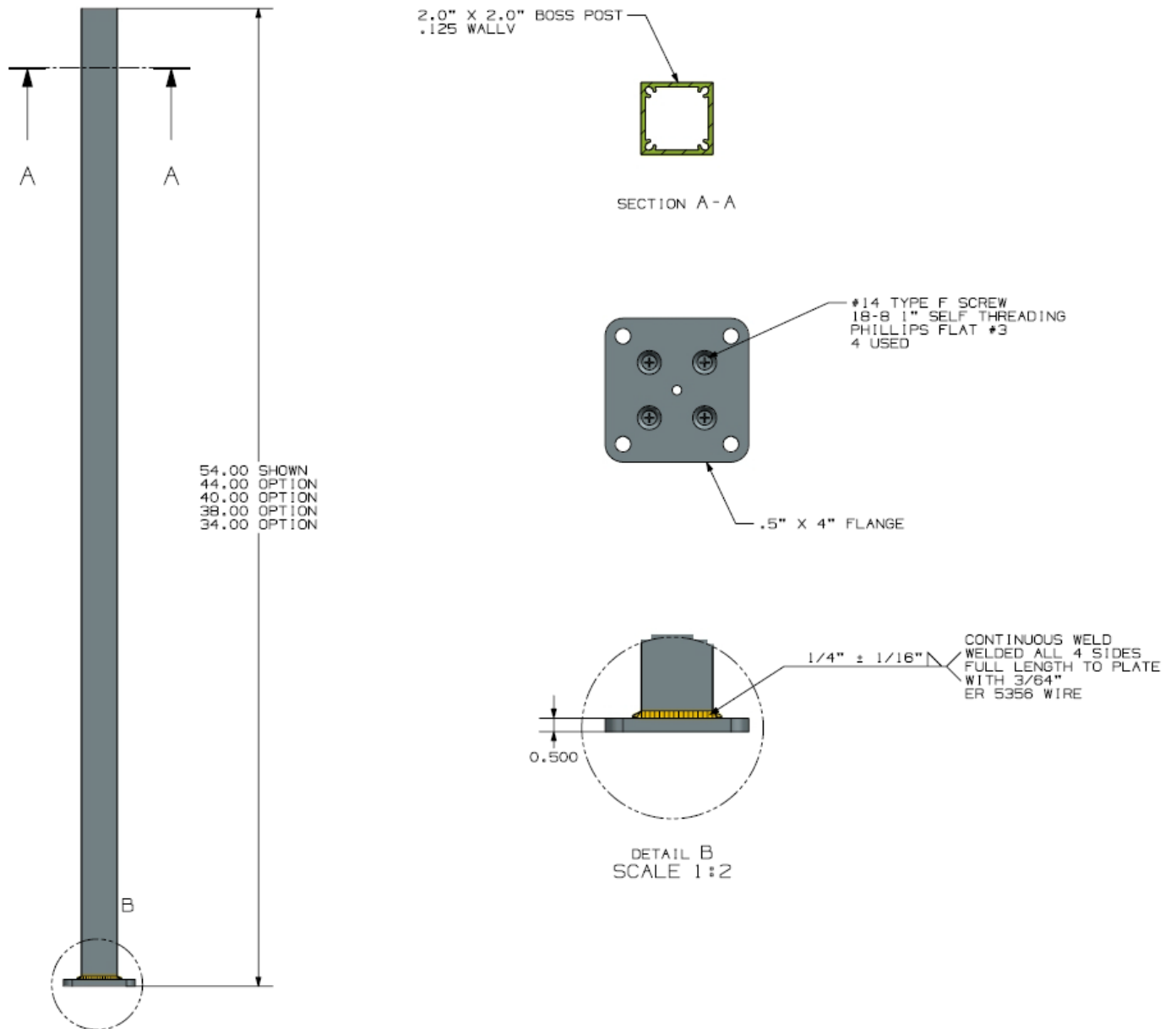

Figure 6 – 2 Inch Aluminum Post

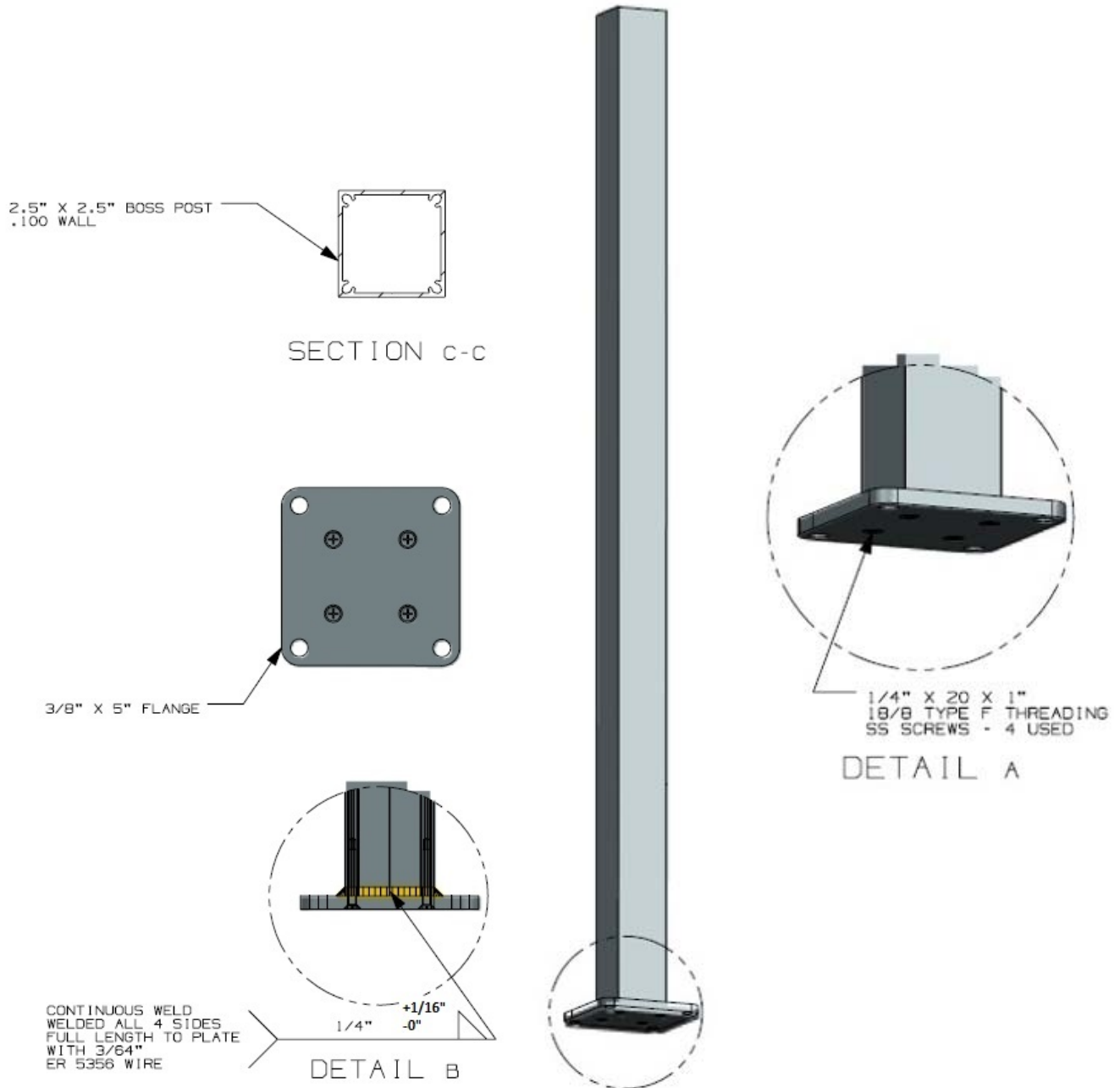

Figure 7 – 2-1/2 Inch Aluminum Post

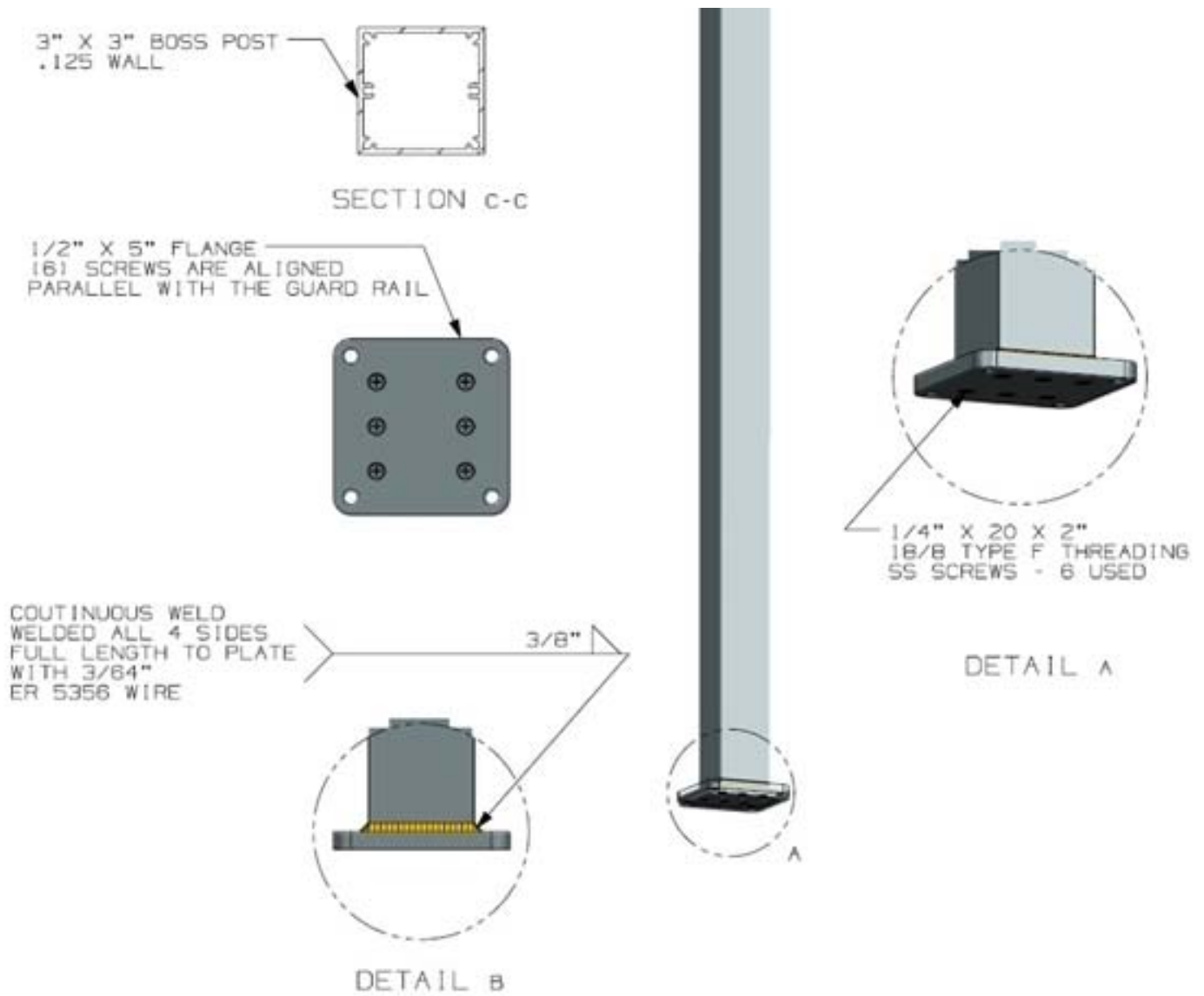

Figure 8 – 3 Inch Aluminum Post (six screw boss)

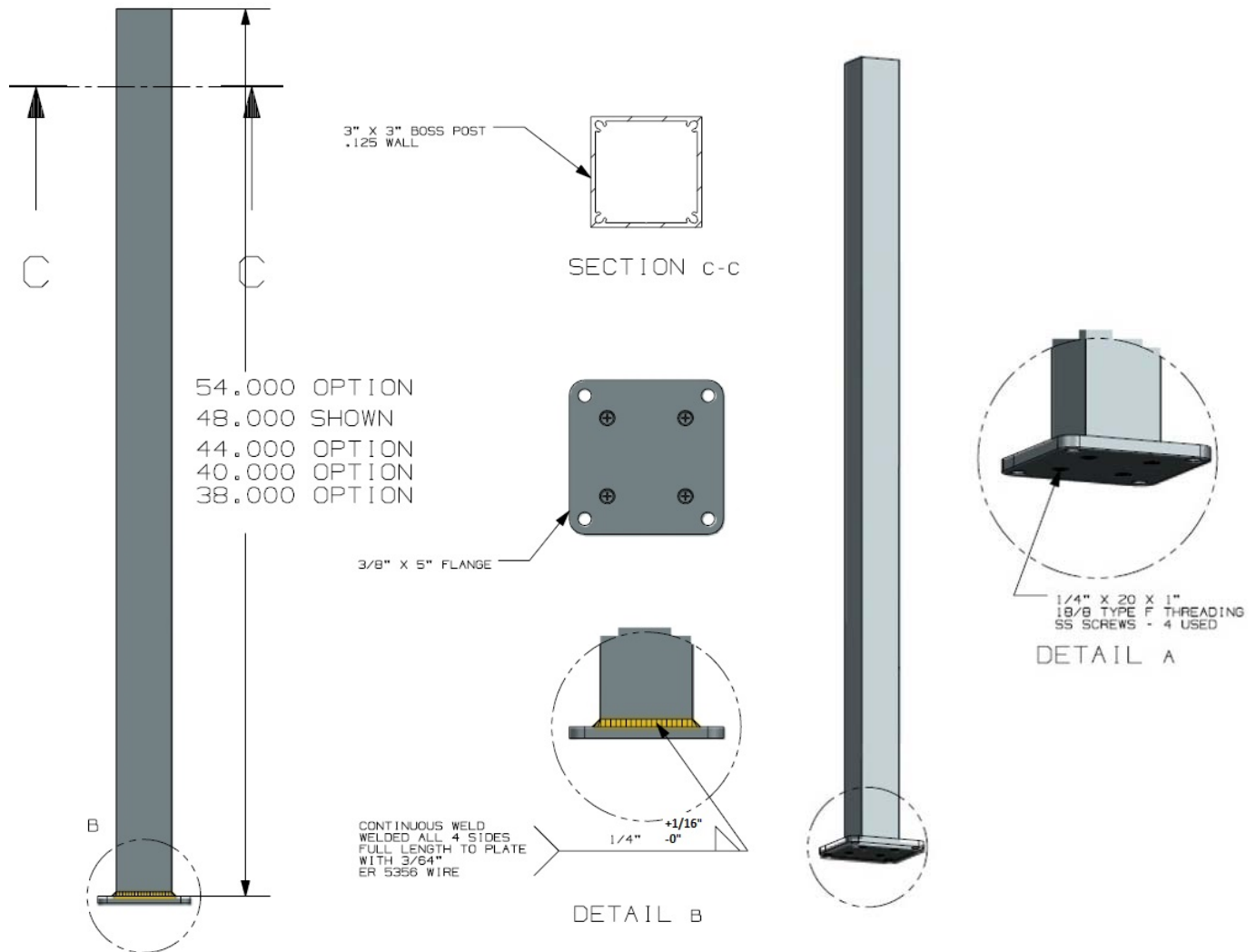

Figure 9 – 3 Inch Aluminum Post (four screw boss)

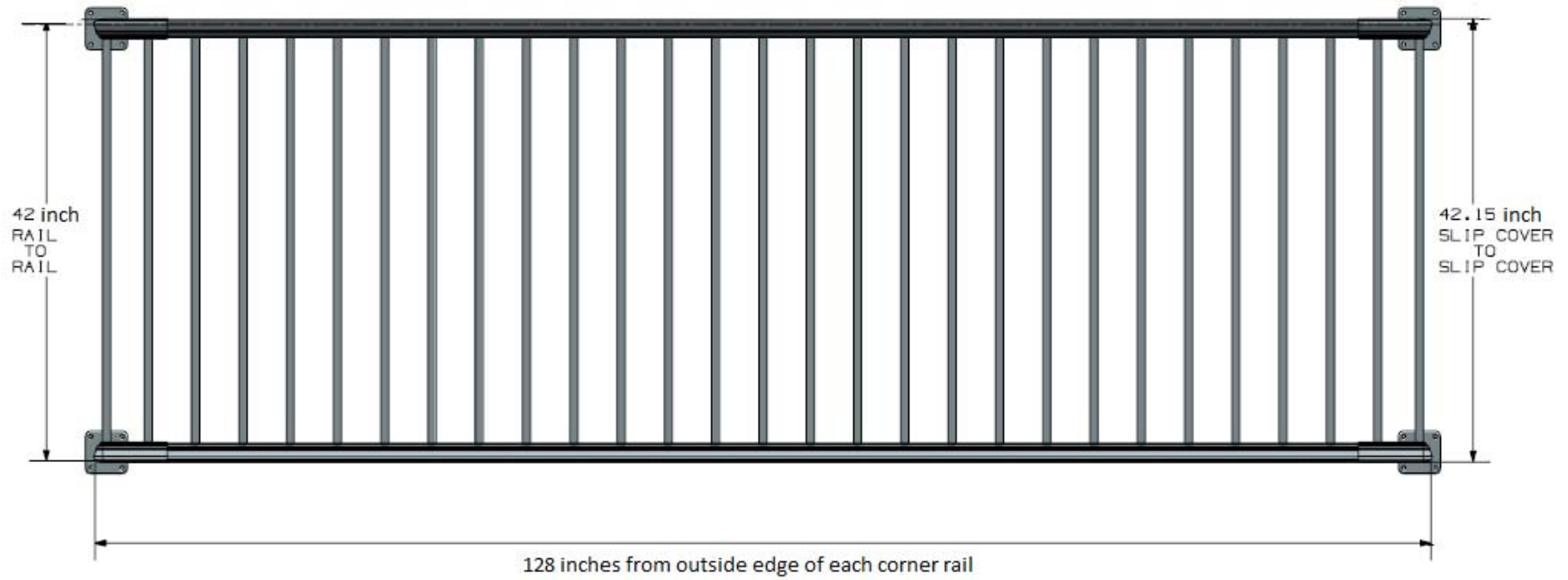

Figure 10 – Juliette Balcony Assembly



545 E. Algonquin Road • Arlington Heights • Illinois • 60005
intertek.com/building

